

COMP5102

Computer Systems

Programming: The Memory Map Model

Mario Gongora

mgongora@dmu.ac.uk

<http://www.cse.dmu.ac.uk/~mgongora>



Overview

- Microcomputer Architecture
- Registers
- Memory
- Peripherals
- The Memory Map Model



Microcomputer Architecture



Microcomputer Architecture

- A microcomputer system has:
 - A CPU (more in detail later)
 - Memory
 - Peripherals
 - A “bus” to connect all
 - Possibly an expansion “bus”
- The CPU executes programs from memory and transfers data (including programs) to and from the peripherals into and out of memory



Registers



Registers

- The CPU works with instructions and data using “registers”
- They serve as a short term memory
- Data or instructions are loaded into registers, processed and written back from the register
- Some have specific purpose:
 - Accumulator, Status, Instruction registers
- Some others are general purpose



Memory



Memory

- The program that is being executed and most working data is held in memory
- The CPU accesses its memory space using addresses, most likely consecutive
- The amount of memory dictates how long a program can be and how much data can it handle at any given moment



Memory

- The speed at which the CPU can access the memory also dictates how fast a program can run.
- Registers are usually faster than memory and also different types of memory can have different speeds
- Massive storage units can make up for extra memory (e.g. Hard Disks) but these are technically peripherals and therefore are slower and programs cannot be executed directly from there



Peripherals



Peripherals

- The computer system communicates with its “outside” world using peripherals
- They provide an interface between the CPU and its registers to any other type of hardware or the user
- They can be:
 - Storage: to have extra space to save data or programs
 - User interfaces: like video, keyboards, sound
 - Sensors and Actuators: to acquire data from a process and to control it



Peripherals

- Peripherals are also accessed using addresses
- Peripherals are normally slower to communicate than memory
- They have their own configuration registers
 - e.g. Baud Rate, resolution, trigger, data Recived, etc...



The Memory Map Model



The Memory Map Model

In conclusion:

- The CPU works and communicates with the world by accessing memory and peripherals using addresses
- The way these addresses are organised is known as the “Memory Map” of the computer system.



The Memory Map Model

- In a computer, the memory map is defined by the design and the parts that are put in it.
 - e.g. in a PC, it depends what devices you connect or install to it
- In a microcontroller, the memory map is defined internally in the chip by the manufacturer and cannot be changed by the user
 - e.g. PIC microcontroller

The Memory Map Model

A typical memory map for a simple Microcontroller:

Program Memory

FIGURE 6-1: PIC16C54/CR54/C55 PROGRAM MEMORY MAP AND STACK

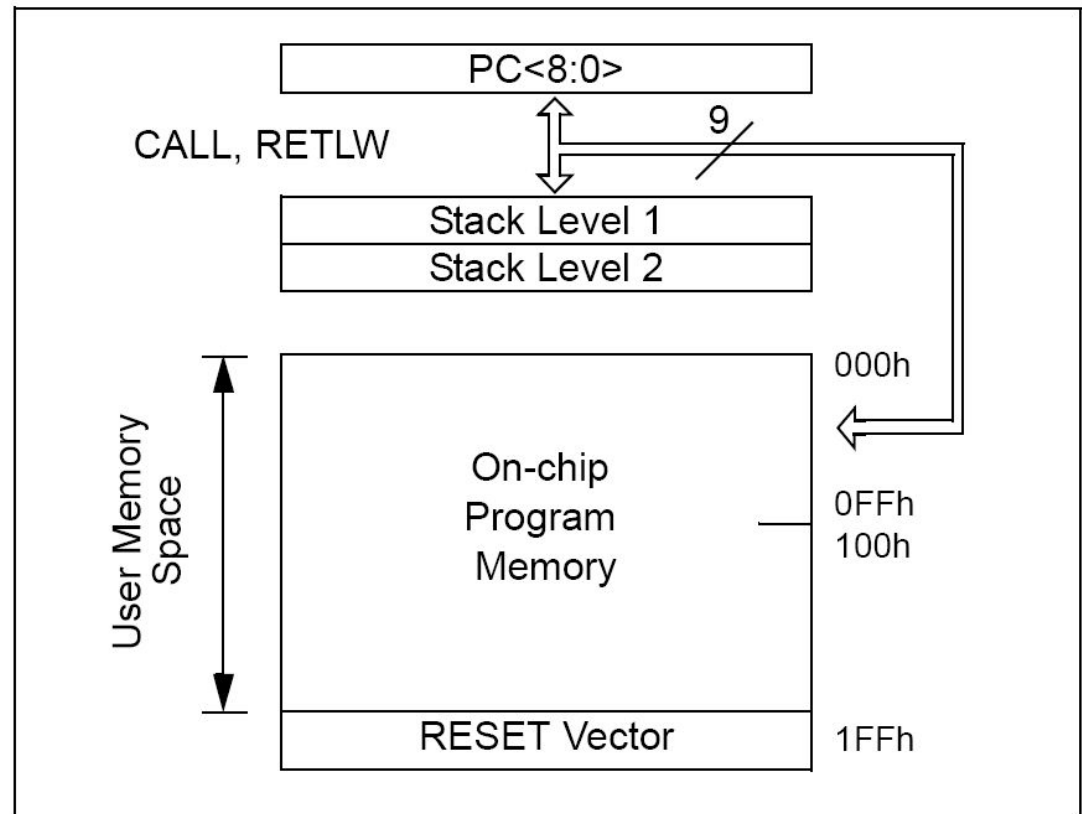

The Memory Map Model

A typical memory map for a simple Microcontroller:

Peripherals Memory
And Registers

FIGURE 6-4: PIC16C54, PIC16CR54, PIC16C55, PIC16C56, PIC16CR56 REGISTER FILE MAP

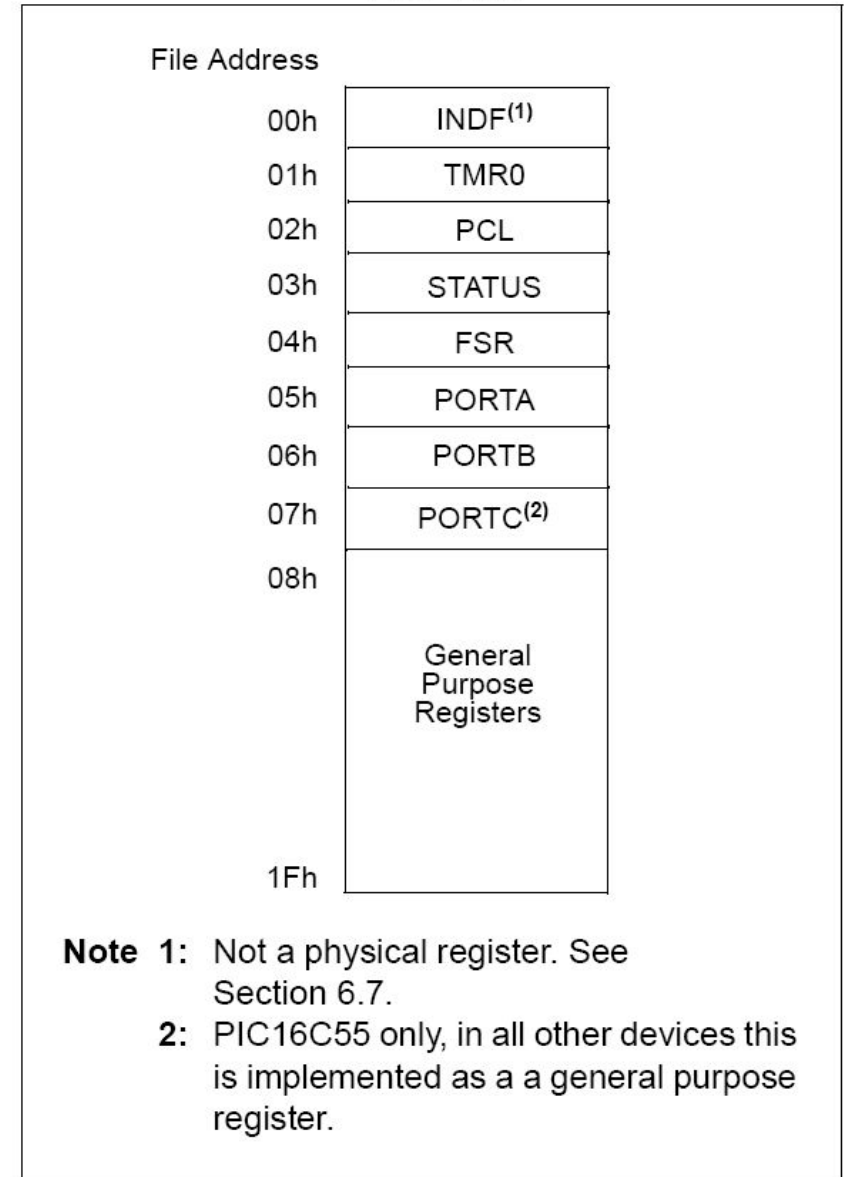

The Memory Map Model

A typical memory map for a simple Microcontroller:
Peripherals Pins

